

How CWM makes the highest quality die cast part at the lowest unit cost

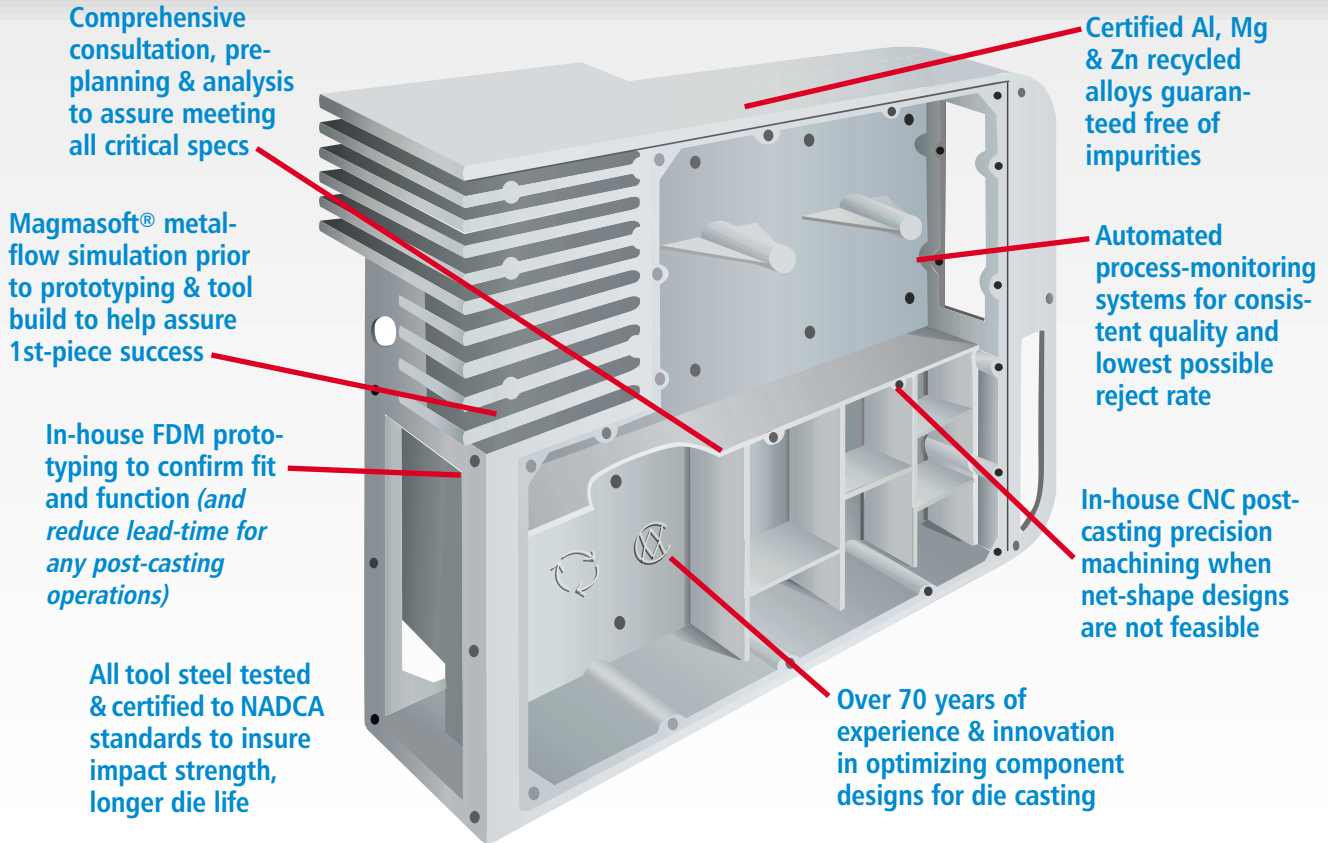

Recent Example



Critical specs, stiffness, light weight

Following prototyping, hot-chamber Mg die casting was chosen for volume production for two medical imager housing sidewalls. Reasons: process stability of die casting and mag's stiffness, light weight and ability to meet critical specs.

Download the details, 1 of 60 PDF aids

The case study, released by permission, is just one of over 60 design and

specification guides for OEM product designers from CWM's Web Resources. For details on this example and downloading the study, plus all OEM design and spec guide listings, go to:

www.cwm-lit.info/wr18

Also visit our website (below) for more on CWM's complete capabilities and the location of your regional CWM Sales-Engineering Representative.

Certified Aluminum,
Magnesium & Zinc
Die Casting and
Miniature Zn/ZA-8

EXCELLENCE IS
EXPECTED



A GREEN BIZ
COMPANY

**Chicago
White Metal
Casting, Inc.**



ISO 9001 Certified Quality Management System
ISO 14001 Certified Environmental Management System

649 North Route 83, Bensenville, IL 60106
Phone: 1-630-595-4424 Fax: 1-630-595-9160

www.cwmdiecast.com